

1084 CANTILEVER LIFT INSTRUCTIONS

OWNER'S MANUAL/1084 SHOREMASTER CANTILEVER LIFT MODELS

EFFECTIVE 1-1-92

Before attempting to operate the lift, read this owners manual thoroughly.

SHOREMASTER

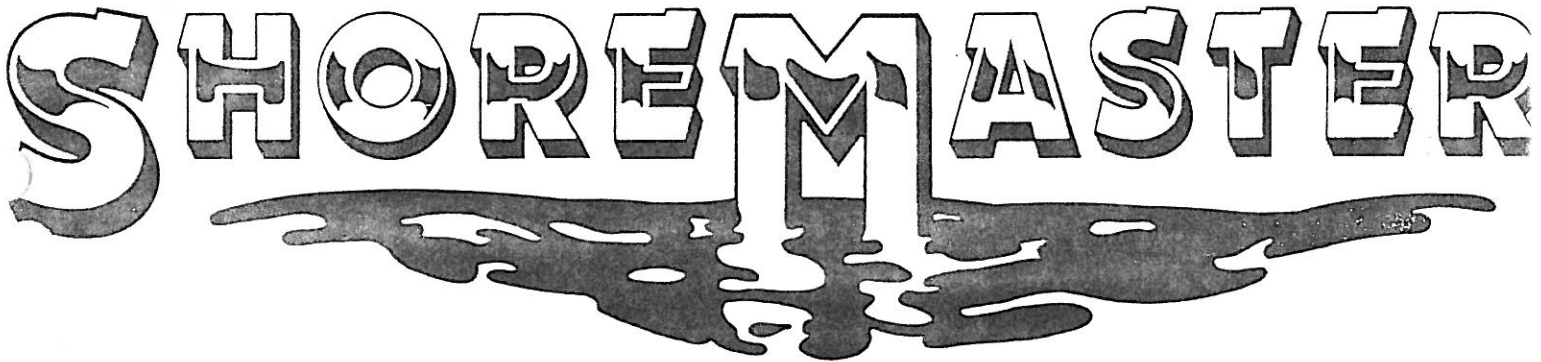

PLEASE KEEP THIS FOR FUTURE REFERENCE

The following parts list, operating/ safety procedures, assembly instructions and maintenance schedule is for your ShoreMaster boat lift. Please read through the manual entirely before attempting to operate the lift. Pay close attention to all safety related material. If you have any questions contact your dealer or call ShoreMaster toll-free (800) 328-8945.

* IMPORTANT **

Grease pulleys and winch when it is new and every spring and fall. Not doing so will invalidate your warranty.

CANTILEVER PARTS LIST

All ShoreMaster cantilever boat lifts have these same general parts. Although they differ in size from one model to another, the general design is the same.

- 4 - Legs (2 front & 2 rear)
- 2 - Sides (left & right)
- 2 - Bottom Beams (front & back)
- 2 - I-Beams (each is the same)
- 1 - Top Rack
- 2 - Side Braces (left & right)
- 2 - Middle Legs (only on #3600 - #5000 models)
- 1 - Wheel
- 1 - Winch Box (assembly hardware, winch, cable, pulleys, bolts, etc.)

Various accessories are available to be mounted on your ShoreMaster lift. Please refer to your brochure or contact your dealer for details and current pricing.

SHOREMASTER INSTRUCTIONAL ASSEMBLY VIDEO'S ARE AVAILABLE FOR PURCHASE OR RENT AT YOUR LOCAL DEALER.

1000# LIFT HARDWARE 1084

<u>QUANTITY</u>	<u>DESCRIPTION</u>
20	3/8" X 2-3/4" MACHINE BOLTS
8	3/8" X 2-1/4" MACHINE BOLTS
2	3/8" X 3" MACHINE BOLTS
30	3/8" NUTS
8	3/8" LOCKING NUTS
14	3/8" FLAT WASHER
2	3/16" CABLE CLAMP

1	DL WHEEL KIT
4	3/8" X 4" U-BOLT
3	PULLEY - PLASTIC
4	#4 BLUE CAP
1	2-LINK 3/8" CHAIN
2	3-LINK 3/8" CHAIN
1	3/16" X 22' CABLE
1	1202 WINCH
1	INSTRUCTION SHEET

**** DO NOT ATTEMPT TO OPERATE LIFT WITHOUT FIRST STUDYING THE FOLLOWING ****

OPERATING & SAFETY

1. After assembly (and yearly), check to be sure that all nuts and bolts are tightened as required. Check pulley sheaves, cable, winch, and lift rack to see that they are all operating freely.
2. Make all possible adjustments to lift legs, cradles, EPU's, and other accessories before installing lift in the water. Adjusting lift parts while in the water is more difficult and potentially more dangerous. NEVER make any adjustments with the boat in the lift.
3. Test to see that the winch is working properly by winding up cable on hub by turning the wheel (or handle) clockwise. The winch should be making a clicking sound. A brake will activate automatically when you stop, allowing you safe and controllable use.
4. ***** IF AT ANYTIME THE WHEEL (OR HANDLE) SPINS UNCONTROLLABLY DO NOT ATTEMPT TO STOP IT !! *****
5. Never attempt to operate lift unless winch is functioning properly.
IMPORTANT: ****IT IS RECOMMENDED THAT ANYONE OPERATING THE LIFT FIRST THOROUGHLY STUDY THE OWNERS MANUAL.** Study winch maintenance, instructions, and safety tips located in your owners manual.
6. Never allow rack to be in a fully lowered position with the boat in it (winter storage etc.). Damage may result to the rack (this applies to cantilever models only).
7. Be sure that the boat is properly balanced and centered on the lift before attempting to raise the rack. Generally, the boat should be as far forward in lift as possible for proper balance.
8. It is recommended that the lift be operated in at least (3) feet of water. This will allow for easier raising of the wheel (or handle) and less strain on the winch (cantilever models only).
9. Do not raise the rack past the recommended height (over center on a cantilever). Doing so could damage the lift or cause the winch or cable to break.
10. DO NOT turn the wheel (or handle) counter-clockwise to the point where the cable begins to develop slack. Doing so may allow the cable to jump the spool and cause personal injury and damage to the winch.
11. If at anytime there is more than the normal resistance when operating the wheel (or handle) and winch, do not attempt to force it. Lower the lift and check for possible problems with winch or other lift parts.

12. NEVER exceed the recommended weight capacity of the lift. Doing so could result in personal injury or irreparable damage to the lift. Also, it would invalidate the lift's warranty.

13. Pull drain plug from boat when not in use. Failing to do so may result in water accumulating and the load exceeding recommended lift capacity.

14. Lock your wheel (or handle) and rack in place by chain and padlock when unattended. This will help prevent theft or possible spin down of wheel (or handle) and rack.

15. Check cable and pulleys for any signs of wear or failure. If this is the case, replace them immediately.

16. Never allow anyone (especially children) on or around lift when in a raised position or when being raised or lowered.

WINCH INSTRUCTIONS, SAFETY & MAINTENANCE

WINCH INSTRUCTIONS

Thread the wheel (or handle) on to the drive shaft turning clockwise until a clicking sound is heard and the rack begins to raise. Making sure the wheel (or handle) remains in firm contact with the brake pads and ratchet gear install the wheel kit to prevent the wheel (or handle) from backing off the winch driveshaft (step 6). Wind cable on winch hub being sure that it raps uniformly to prevent fraying or binding.

Wind cable off the hub by turning counter-clockwise (no noise will be produced). The wheel (or handle) will then remain in position when the wheel (or handle) is released. Sufficient load must be applied to lift for brake mechanism to activate properly, otherwise turning the wheel (or handle) will only remove the wheel (or handle) from the shaft. Always satisfy yourself that the winch brake is holding the load before releasing the wheel (or handle). If it is not, rapid spin down could occur. DO NOT attempt to stop wheel (or handle) if this should happen.

If at anytime the wheel (or handle) turns down with great difficulty, the brake may not have released. The brake pads may be worn or not smooth enough to allow brake to release. It is important that the wheel (or handle) and shaft threads are greased periodically. DO NOT, however, grease any part of the brake mechanism.

* IMPORTANT *

NEVER wind cable off the winch hub so that excess slack occurs in the cable. Excess slack in the cable could allow the cable to slip off the winch hub or pulleys and cause damage to your lift or winch and may cause personal injury.

SAFETY

The winch for this lift is strickly for lifting operations. It is not to be used as a method of supporting or transporting people, or for loads over areas where people may be present.

Check winch for proper operations on each use. If it is damaged in anyway do not attempt to operate.

Never allow children or those unfamiliar with the operation of the lift to use it.

Never exceed recommended lift capacity. Personal injury may result.

Never apply load to winch with cable fully extended. There should be at least four full turns of cable on the hub.

WINCH MAINTENANCE

It is recommended that the winch be inspected periodically (twice yearly). Necessary preventive maintenance is required for maximum performance of the winch.

1. Remove all of load from the lift until cable BEGINS to slack. Remove wheel kit and wheel (or handle) from shaft.
2. Remove clutch plates and ratchet gear from shaft. Sand off any rust or corrosion on these parts. DO NOT grease the clutch mechanism.
3. Replace clutch plates and ratchet gear on the shaft. One clutch plate should be on each side of the ratchet gear. Replace wheel (or handle) and wheel kit.
4. Check to be sure that ratchet pawl and spring are aligned on the ratchet gear. You can do this by turning the wheel (or handle) clockwise. A clicking sound should be heard. If it is not functioning properly, check to see that your spring is in place. There must be tension in the springs for pawl to ratchet properly.
5. Check to see that gears, shafts and chains are attached and turning freely. Grease all bearings and gear teeth with good wheel bearing grease.
6. Replace winch cover. Check mounting of winch to be sure that it is secure and properly aligned. Also, check cable to make sure it is secure and there is no abnormal stiffness or broken strands.
7. Replace any worn or broken parts with authorized ShoreMaster parts available at your local dealer or ShoreMaster.

ELECTRIC POWER UNIT SAFETY

** WARNING **

1. Always turn off MAIN POWER SUPPLY when moving or working on or around lift.
 2. It is recommended that power be shut off or motor unplugged when not in use to preserve the life of the motor.
 3. Proper care should be exercised in regard to wires which are exposed to wave or wind oscillations. Kinks or breaks in wire could occur, resulting in SERIOUS INJURY!
 4. It is recommended that an electrician do the installation and final inspection of this Electric Power Unit.
- ** Not complying with the above recommendations may invalidate the warranty or result in personal injury.

STEP 1

****IMPORTANT****

DO NOT FULLY TIGHTEN BOLTS & NUTS UNTIL YOU ARE FINISHED WITH ASSEMBLY

- (A) INSERT ALL (4) LIFT LEGS INTO LIFT SIDES AND BOLT IN PLACE USING 3/8" X 2 3/4" MACHINE BOLTS.
- (B) SET LIFT SIDES UP AS SHOWN ABOUT 10 FEET APART. THE TRIANGULAR PLATES ON THE LIFT SIDES SHOULD BE ON THE OUTSIDE.
- (C) BOLT THE FRONT & REAR BOTTOM BEAMS TO THE LIFT SIDES USING 3/8" X 2 3/4" MACHINE BOLTS. THE BOTTOM BEAM THAT HAS THE SQUARE PLATE IS THE REAR BOTTOM BEAM AND THE BOTTOM BEAM THAT HAS THE RECTANGULAR PLATE IS THE FRONT BOTTOM BEAM.

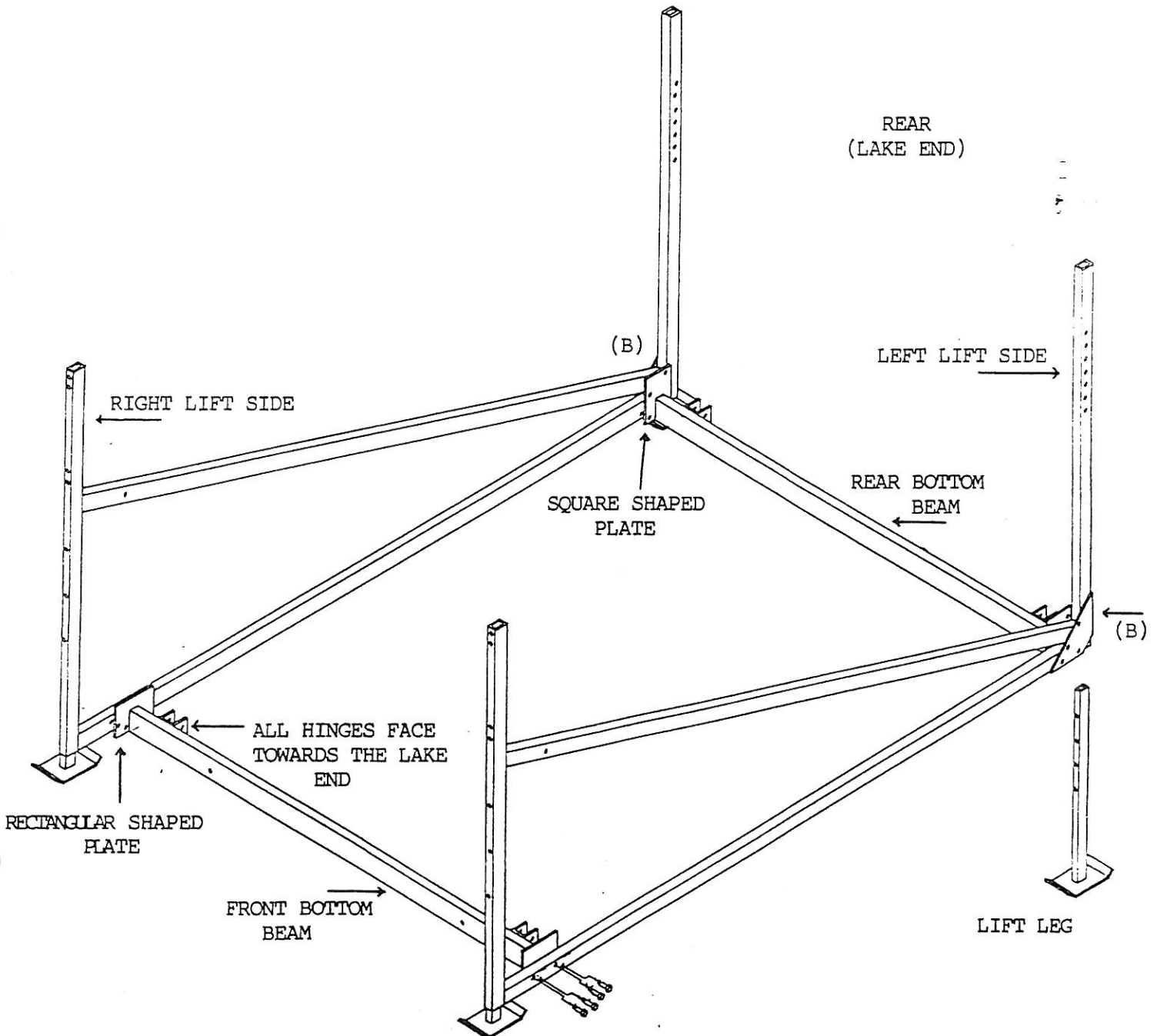

STEP 2

- (A) ATTACH EACH I-BEAM TO THE FRONT & REAR BOTTOM BEAMS AS SHOWN USING 3/8" X 2 1/4" MACHINE BOLTS AND LOCKING NUTS. EACH I-BEAM IS THE SAME. DO NOT OVERTIGHTEN TO ALLOW FREE SWIVEL.
- (B) ATTACH EACH LIFT BRACE AS SHOWN USING 3/8" X 2 3/4" MACHINE BOLTS. THE SLOTTED OR FORKED END CONNECTS TO THE LIFT SIDE AND WASHERS ARE RECOMMENDED TO BE USED HERE. THE OTHER END OF THE BRACE CONNECTS TO THE FRONT BOTTOM BEAM. THE BRACES SHOULD BE TIGHTENED SO THAT THE LIFT SIDES ARE NOT BOWING IN OR OUT.

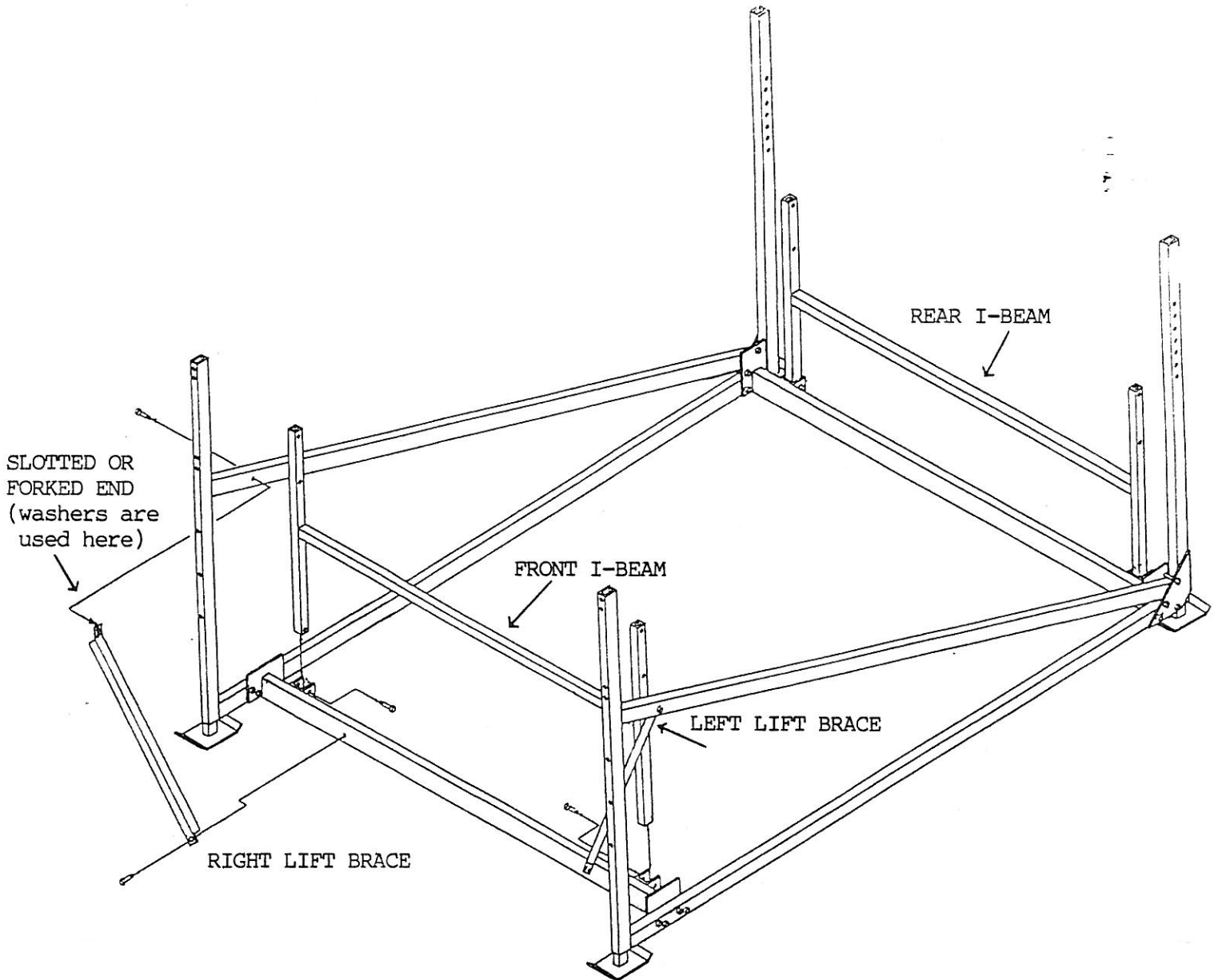

STEP 3

- (A) ATTACH THE TOP RACK TO THE I-BEAMS AS SHOWN USING 3/8" X 2 1/4" MACHINE BOLTS AND LOCKING NUTS. DO NOT OVERTIGHTEN TO ALLOW FREE SWIVEL.

****NOTE****

MAKE SURE THE HINGES ON THE TOP RACK FACE TOWARD THE FRONT OF THE LIFT AND THAT THE TRIANGULAR PLATES (GUSSETS) IN ALL (4) CORNERS OF THE TOP RACK FACE UPWARD.

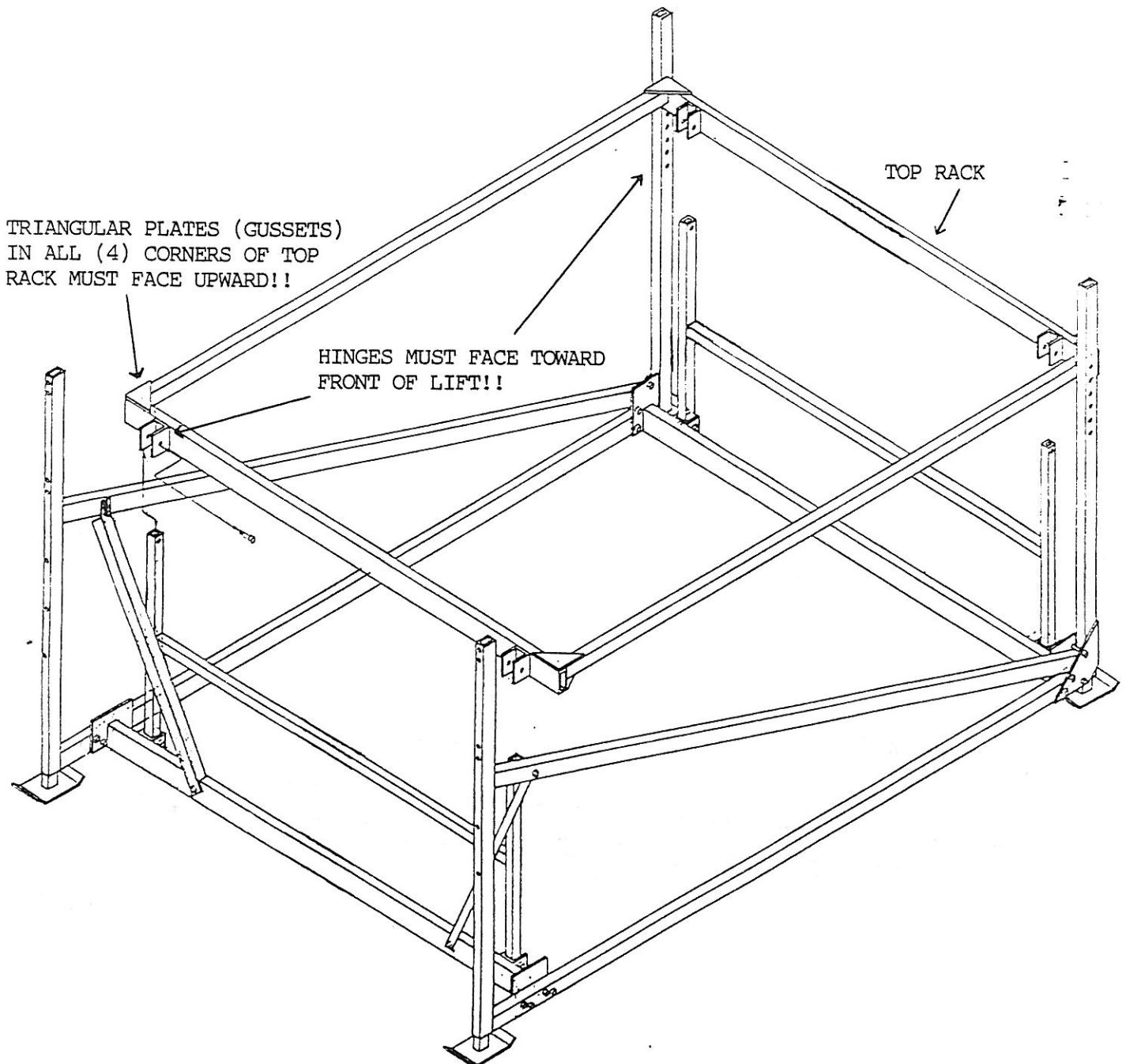

**GREASE PULLEYS

STEP 4

**BEFORE BEGINNING - IT MAYBE HELPFUL TO TIE THE RACK IN A RAISED POSITION BEFORE ATTACHING THE FOLLOWING PARTS.

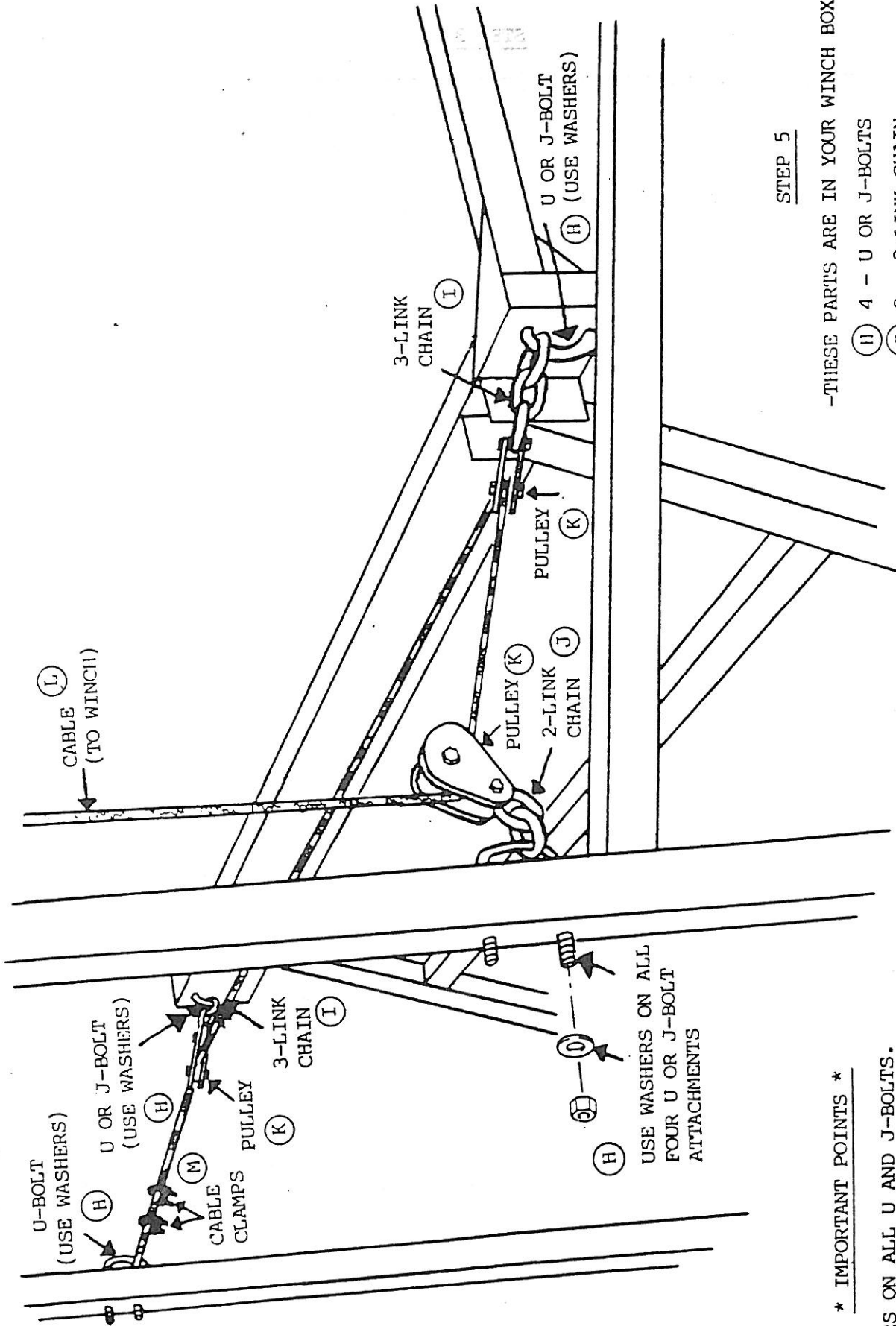

STEP 5

-THESE PARTS ARE IN YOUR WINCH BOX

- (H) 4 - U OR J-BOLTS
- (I) 2 - 3-LINK CHAIN
- (J) 1 - 2-LINK CHAIN
- (K) 3 - PULLEYS
- (L) 1 - CABLE
- (M) 2 - CABLE CL.A. S

* IMPORTANT POINTS *

1. USE WASHERS ON ALL U AND J-BOLTS.
2. A U-BOLT IS USED WHEN ATTACHING TO THE SIDES.
3. A U-BOLT OR J-BOLT IS PROVIDED TO ATTACH CHAIN LINKS AND PULLEYS TO THE TOP RACK (DEPENDING ON MODEL).
4. GREASE PULLEYS WHEN NEW AND EACH SPRING AND FALL.
5. TIGHT. CABLE CLAMPS SECURELY.

STEP 5

IMPORTANT

TO MOUNT A DUTTON-LAINSON WINCH ON THE OPPOSITE SIDE OF THE LIFT ALL THAT NEEDS TO BE DONE IS TO TURN THE WINCH UPSIDE DOWN AND MOUNT IT ON THE OPPOSITE UPRIGHT.

- (A) ATTACH THE LIFT CABLE TO THE WINCH THROUGH THE HOLE PROVIDED IN THE HUB AND SECURE IT BY USING A CLAMP THAT IS LOCATED IN THE WINCH BOX.
- (B) ATTACH THE WINCH TO THE FRONT UPRIGHT OF THE LIFT SIDE USING 3/8" X 3" MACHINE BOLTS AND WASHERS. PLEASE MAKE SURE THE WINCH IS AS STRAIGHT UP AND DOWN AS POSSIBLE.
- (C) TURN THE LIFT WHEEL ON THE THREADED SHAFT OF THE WINCH UNTIL IT IS SNUG AGAINST THE CLUTCH PADS.
- (D) MAKING SURE THE LIFT WHEEL REMAINS SNUG AGAINST THE CLUTCH PADS, ATTACH THE WHEEL KIT BY TURNING THE LOCK BOLT, WASHER, AND SPACER ON SNUG. DO NOT OVERTIGHTEN THE WHEEL KIT. THE WHEEL KIT IS LOCATED IN THE WINCH BOX.

NOTE

PLEASE BE SURE TO USE WASHERS WHEN MOUNTING THE WINCH!!

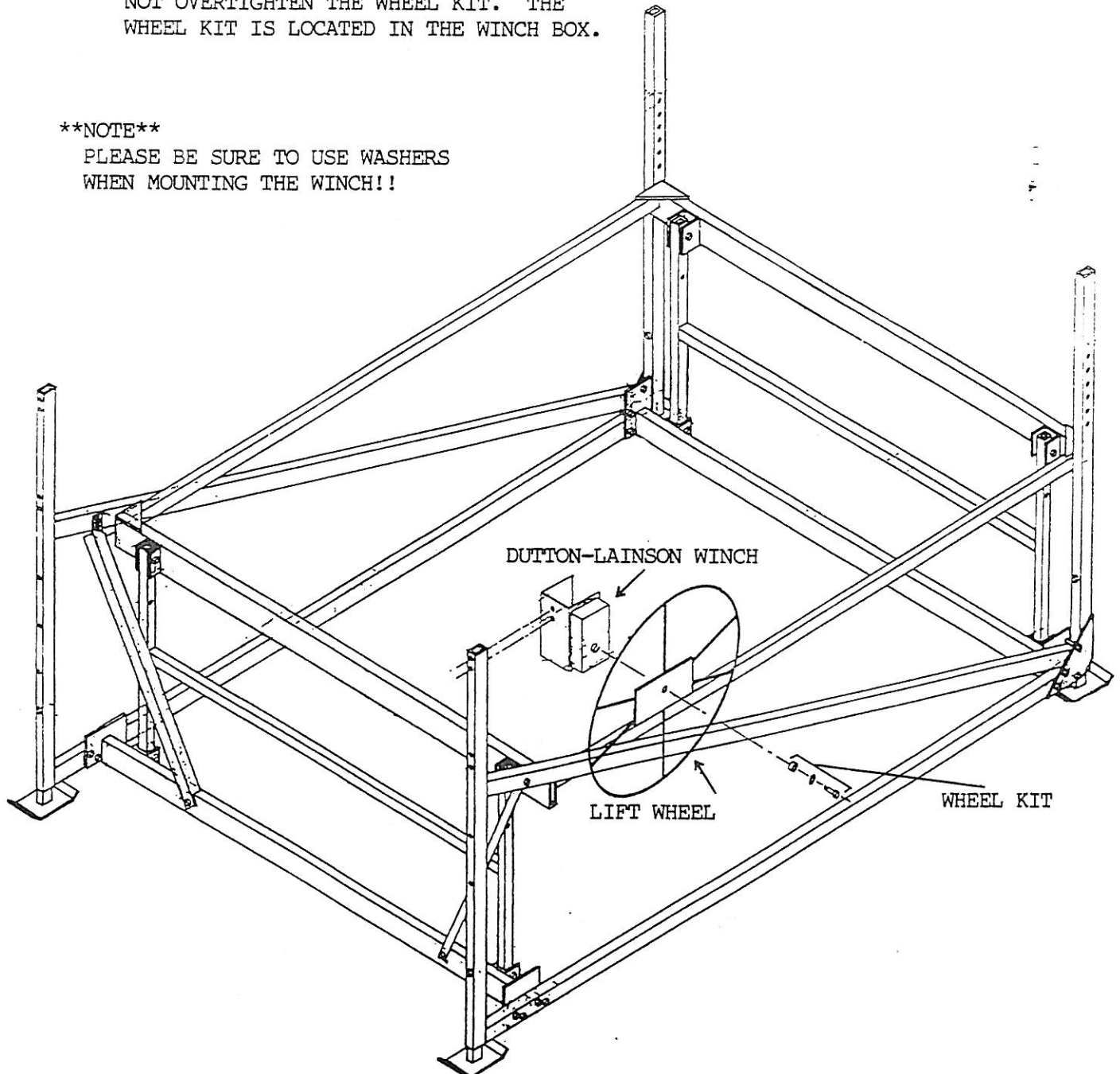

SHOREMASTER CANOPY INSTRUCTIONS

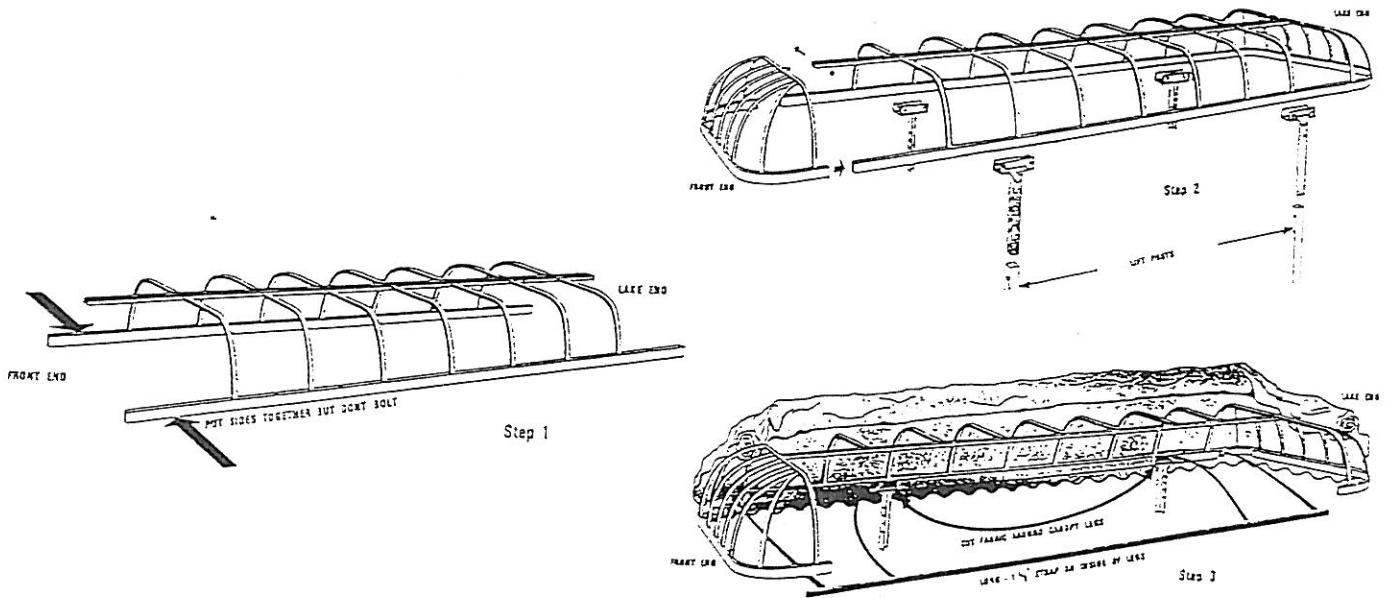

SHOREMASTER CANOPY ASSEMBLY INSTRUCTIONS

All Shoremaster canopies have 7 main parts. Namely that of (2) sides, (2) ends, (4) canopy legs for mounting to the boat lifts and (1) vinyl cover. Also included are (6) aluminum flat straps, (18-20) springs and a bolt bag.

1. To begin assembly, place sides and ends in approximate position. Telescope end pieces into canopy sides. The sides can now be bolted together.
2. Bolt canopy legs to the boat lift by telescoping the canopy legs into the top of the lift uprights.
3. Mount canopy frame on boat lift by placing the canopy frame into the U-shaped pieces on top of the canopy legs and bolt into place.
4. Place vinyl cover over canopy frame. The cover will fit snug. It is recommended that the weather be reasonably warm when placing the cover on the canopy frame.
5. The vinyl cover is secured to the canopy frame by the following method.
 - 1.) Two slits should be cut into the flap in the bottom of the vinyl cover on each side of the (4) legs that connect the canopy frame to the lift.
 - 2.) The aluminum flat straps are telescoped into the flap in the bottom of the vinyl cover.
 - 3.) The springs attach to the flat straps and ribs or bows on the canopy frame.
 - 4.) This will insure a snug and uniform fit.

**** ATTENTION ****

CANOPY FRAMES ARE NOT DESIGNED TO SUPPORT EXCESS WEIGHT. ALWAYS REMOVE VINYL COVERS DURING INACTIVE WINTER MONTHS. ESPECIALLY IN AREAS WITH EXTENSIVE SNOWFALL!!

CANOPY SAFETY PRECAUTIONS & MAINTENANCE

- (1) Canopy frames are not designed to support excess weight. Always remove vinyl covers during inactive winter months, especially in areas with extensive snowfall.
- (2) Remove the vinyl cover when taking the lift out of the water for any reason (winter storage, repair, etc.) or if the boat is going to be out of the lift for an extended period of time.
- (3) When storing your vinyl during the inactive season, please make sure the vinyl is dry before folding and storing. Also, please store the vinyl in a warm, dry location to assure the best results.
- (4) Do NOT use chemicals to clean the vinyl cover. Use soft soap and water. Contact ShoreMaster Fabric Division to obtain further information on cleaning.

NON-ADJUSTABLE CRADLES

1. Bolt the cradle leg and rubber onto the cradle channel as shown in the picture. NOTE - Bolt the cradle leg to the cradle channel using the small hole in the cradle channel.
2. Straddle the cradle channel over the top of the front rack beam, line up the large hole in the cradle channel with the hole in the front rack beam and bolt in place.
3. The cradle leg sits on top of the front rack beam.

** NOTE **

The cradle pockets are not used with non-adj. cradles.

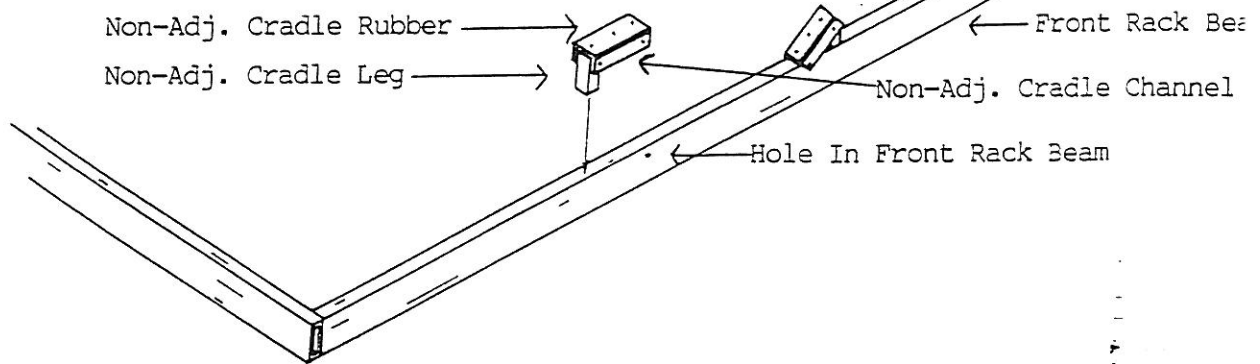

ADJUSTABLE CRADLES

1. Bolt the cradle leg and rubber onto the cradle channel as shown in the picture.
2. Lower the cradle leg into the cradle pocket and bolt into place at the desired height.
3. Adjust the cradle channel to the desired angle and tighten securely into place.

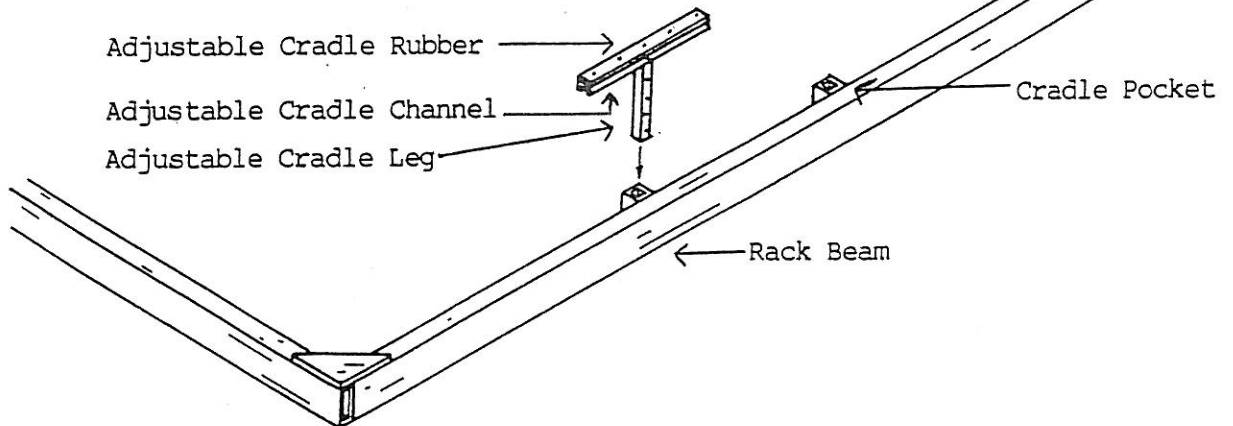

** NOTE **

The cradle channel is adjustable so the adjustable cradle can run either perpendicular or parallel with the boat.

GUIDE-ONS

1. Place the guide-on channel over the front and/or rear rack beam from the outside.
2. Adjust to the desired width.
3. Bolt into place.

**** NOTE ****

All the bolts should be facing the middle of the rack to eliminate exposed jagged edges.

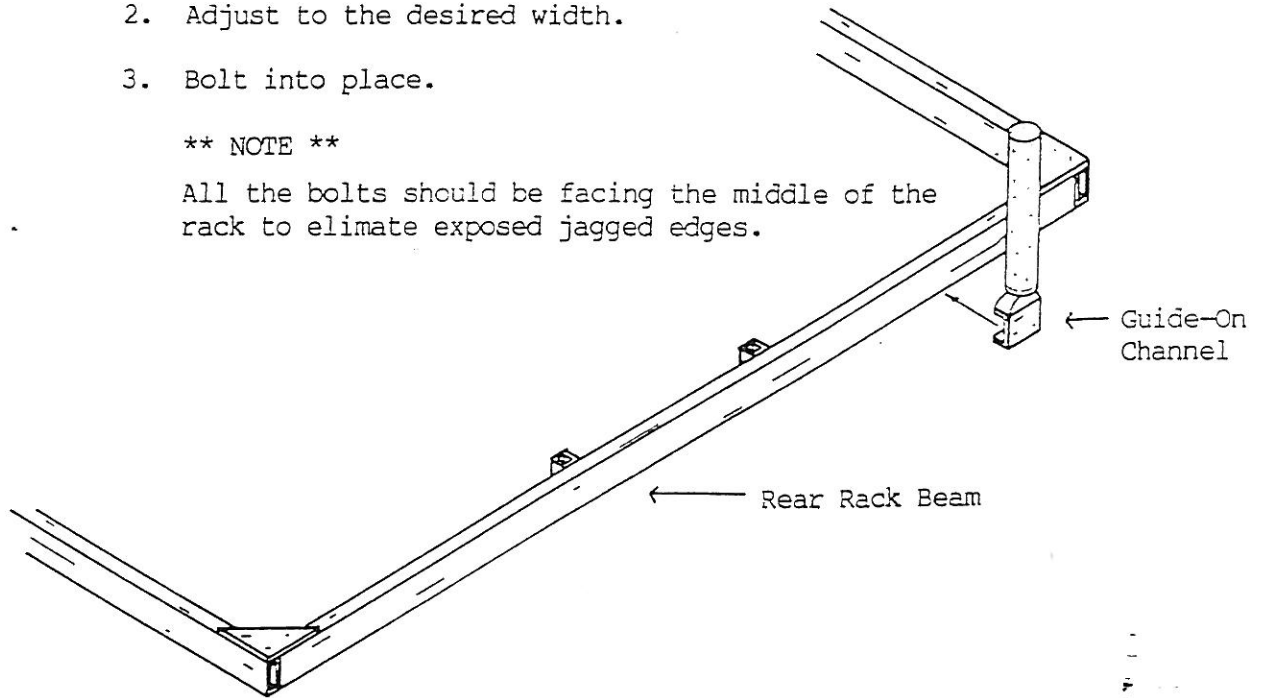

ADJUSTABLE MOTOR STOP

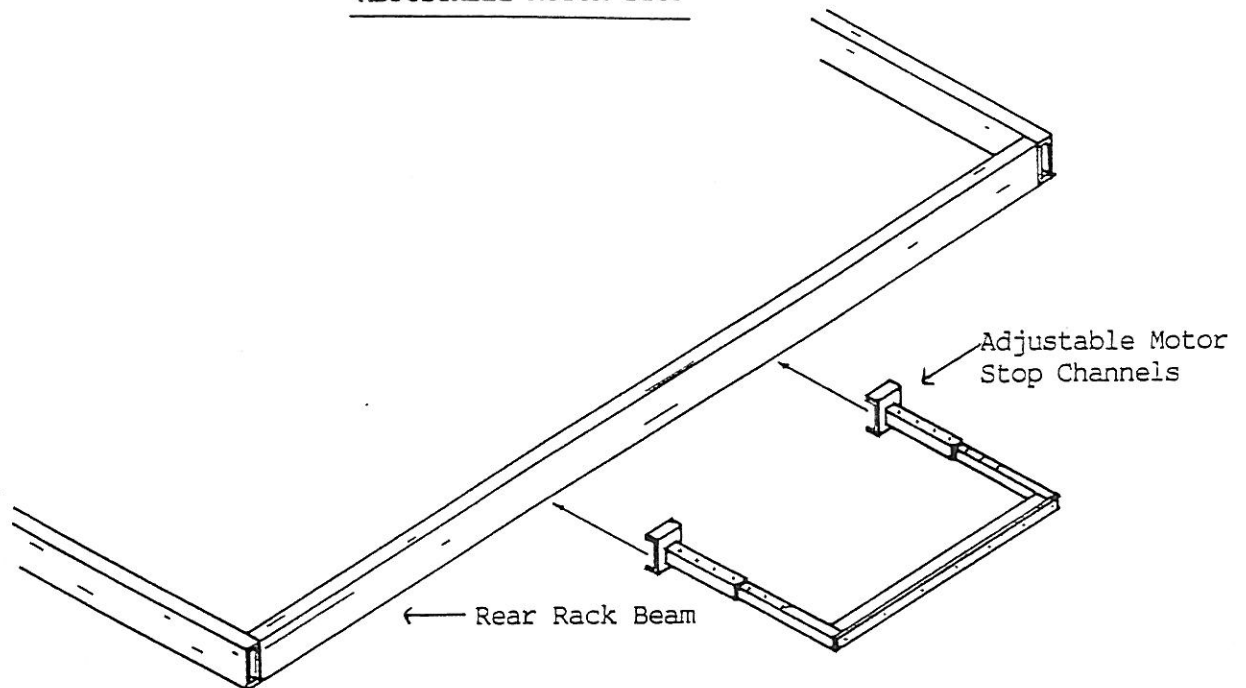

1. Place the adjustable motor stop channels over the rear rack beam, center, and bolt into place.

LIFT SIDE BUMPER

- (1) Place each lift side bumper on the insides of the rear uprights and bolt in place so the nut on the bolt is on the outside of the rear upright.

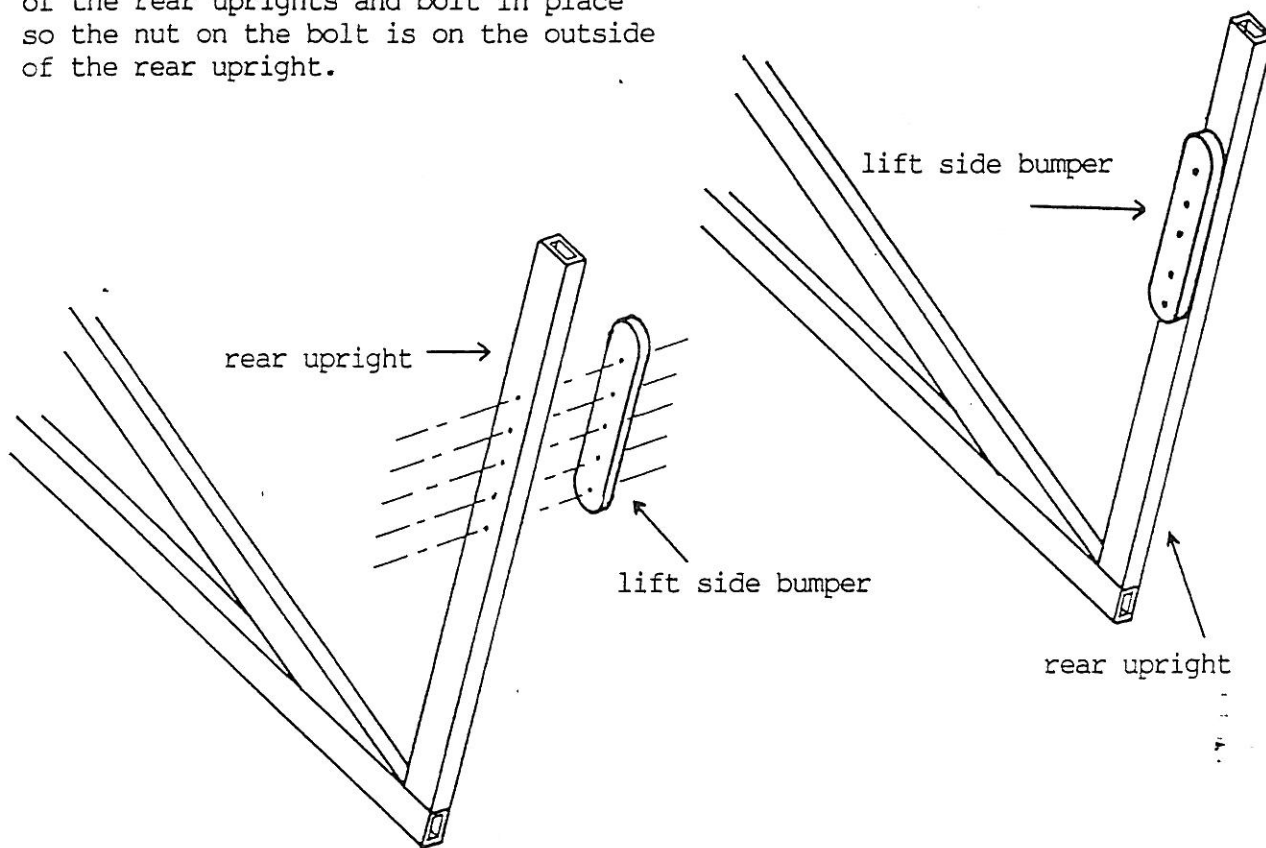

18" BUNK BRACKET

- (1) Slide the adjustable cradle pocket over the front and/or rear rack beam and bolt in place.
- (2) Slide the cradle leg into the adjustable cradle pocket and bolt in at the desired height:

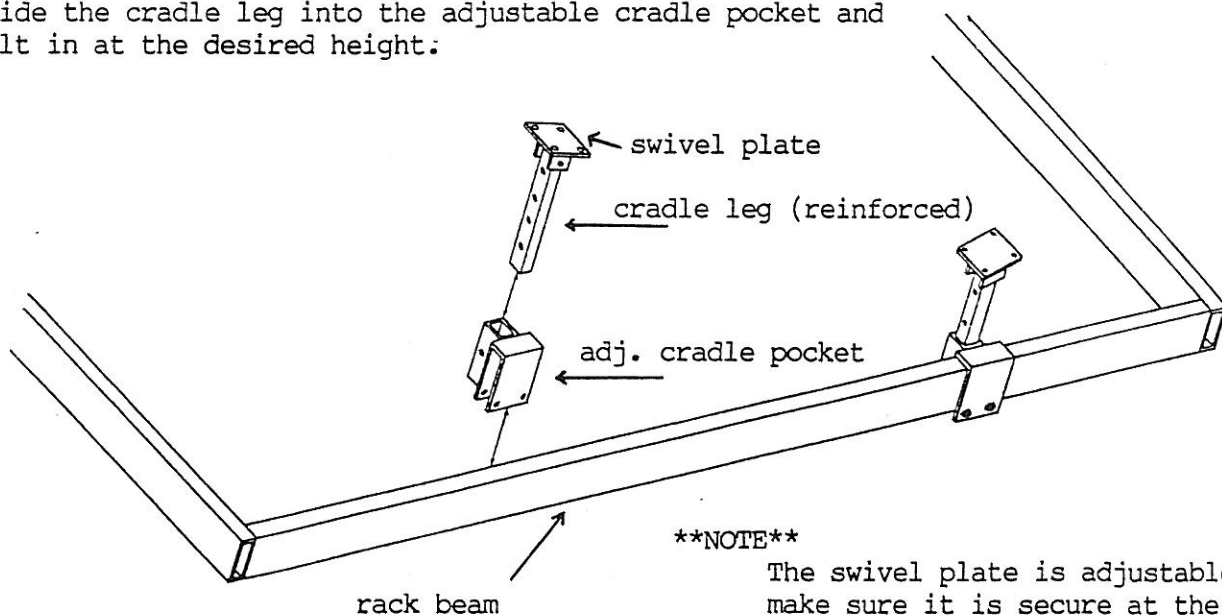

PARTS PRICE SHEET
B-1200 WINCH

<u>REF. LETTER</u>	<u>PART NAME</u>
A	WINCH BASE ASSEMBLY
B	OILITE BEARING
C	RATCHET WHEEL
D	REEL BOLT
E	BRAKE LINERS (FIBER CLUTCH)
F	BRAKE WINCH HUB ASSEMBLY
G	SELF TAPPING SCREW (EACH)
H	GEAR COVER
J	DRIVE SHAFT ASSEMBLY
K	REEL ASSEMBLY 1-1/8" HUB
KA	REEL ASSEMBLY 2-1/2" HUB
L	ROLL PIN
M	WINCH HANDLE ASSEMBLY
N	RATCHET PAWL SPACER BUSHING
O	BRAKE RATCHET SPRING
P	RATCHET PAWL
Q	RATCHET PAWL BOLT
R	CARRIAGE BOLT
S	1/4" HEX NUT
T	ROPE CLAMP
U	3/8" LOCKNUT (EACH)
V	SPACER SLEEVE
Y	9/16" NEEDLE BEARING
Z	SPACER WASHER
AA	RETAINER RING
DD	SPRING
EE	SHAFT EXTENSION
FF	RETAINER WASHER
GG	HEX BOLT

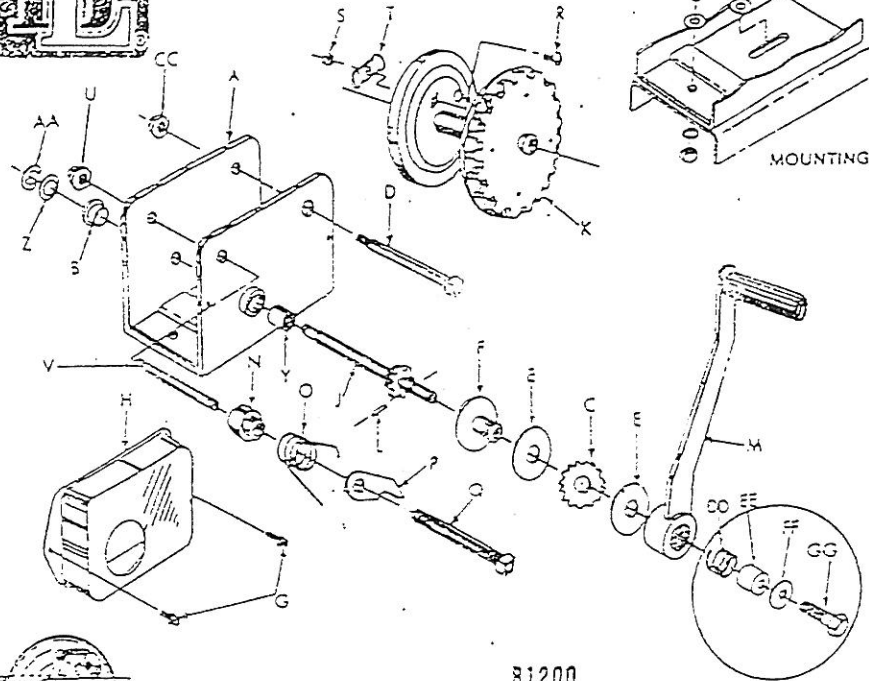

CABLE ATTACHMENT

81200
GEAR RATIO - 4:1
LOAD CAPACITY - 1200 LBS.
REEL CAPACITY - 7.32" DIA. CABLE, 58 FT.